

141 Rodeo Drive
 Edgewood, NY 11717
 Phone: 631.789.5000
 Fax: 631.789.5063
 Toll Free 888.844.4720
 sales@tiitech.com
 www.tiitech.com

INSTALLATION NOTES



MODEL: FDH9 MODULAR SPLITTER CABINET

1. PAD MOUNT

1.1 Use provided template to drill concrete pad and install anchors in the right locations. Attach cabinet base to previously installed anchors. Holes on mounting base can accommodate 3/8" or 5/16" mounting bolts.

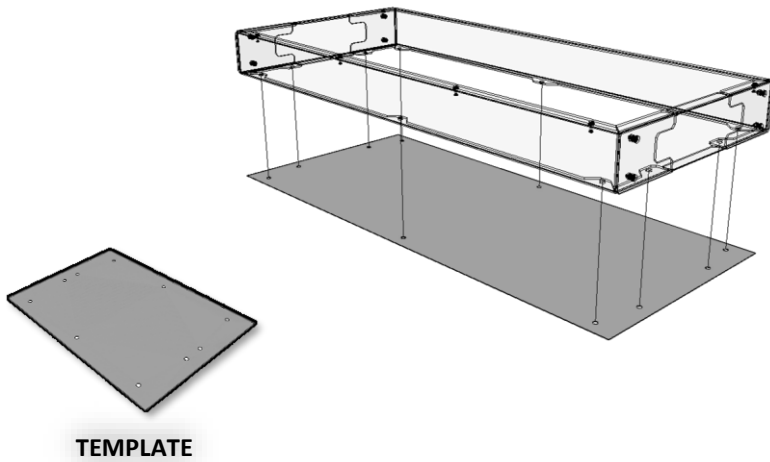

1.2 Slide cabinet over mounting base so the bracket on the back of the cabinet engages the lip of the base.

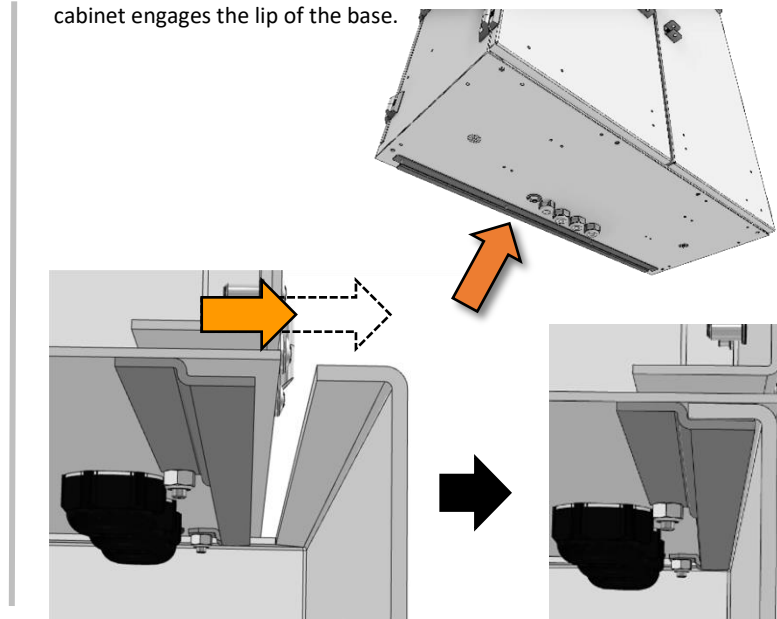

1.3 Secure with 3 screws from inside the cabinet as indicated above.

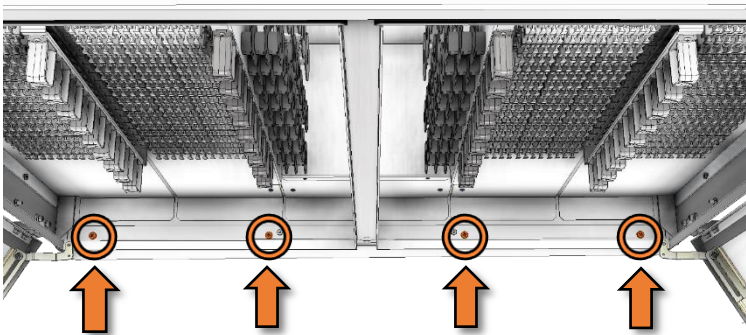

2. GROUNDING THE CABINET

2.1 Open the back side doors with 216 tool.



2.2 Open the doors until the locking pin snaps into their secure position

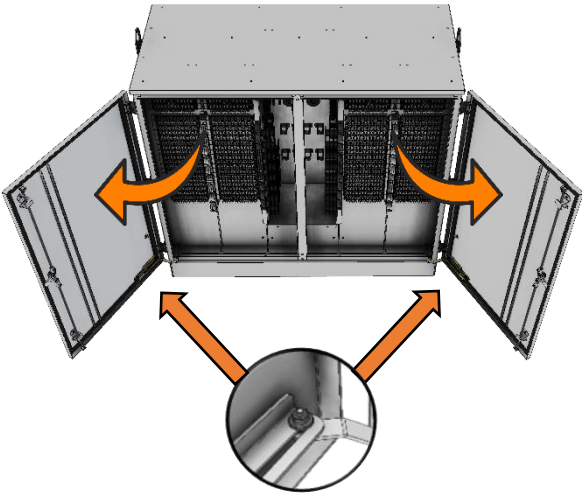

2.3 Bring grounding cable thru provided holes on bottom of cabinet, and securely fix to grounding bar.

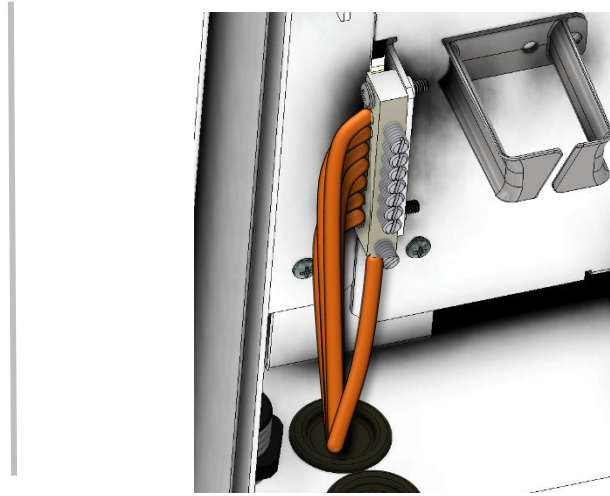

3. ADDING/SPLICING TO/ SERVICING A CASSETTE

3.1 Remove the feeder cassette by releasing the mounting pins (located on both sides of the cassette as shown), slide the cassette rearward to remove.

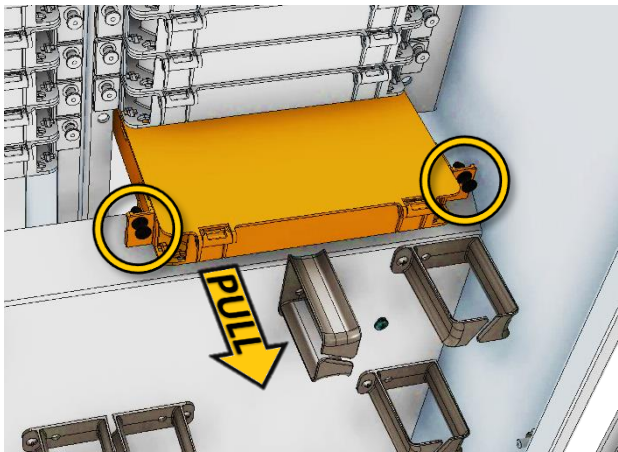

3.2 Insert feeder cable thru small cable port, tighten external nut, secure jacket with hose clamp and fix strength member as indicated.

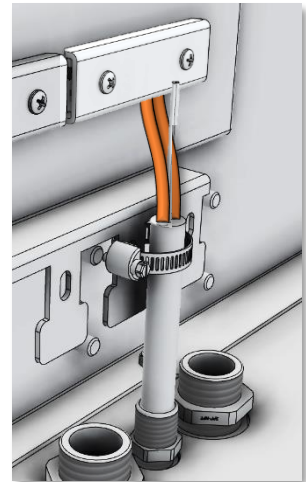
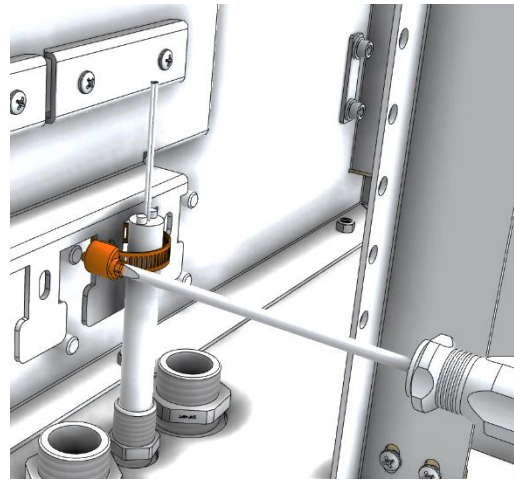

3.3 Make all required fusion splices inside feeder cassette.

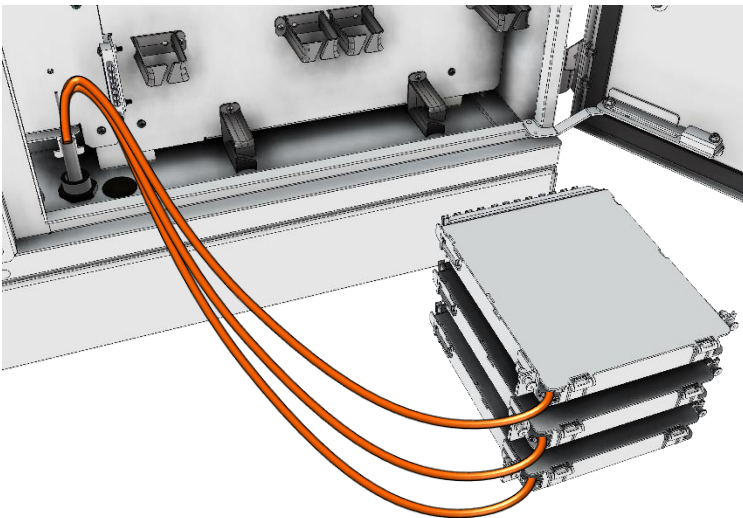

3.4 Store feeder cable slack on provided cable management clips. Mount feeder cassette back in place and secure them by pushing the pins.

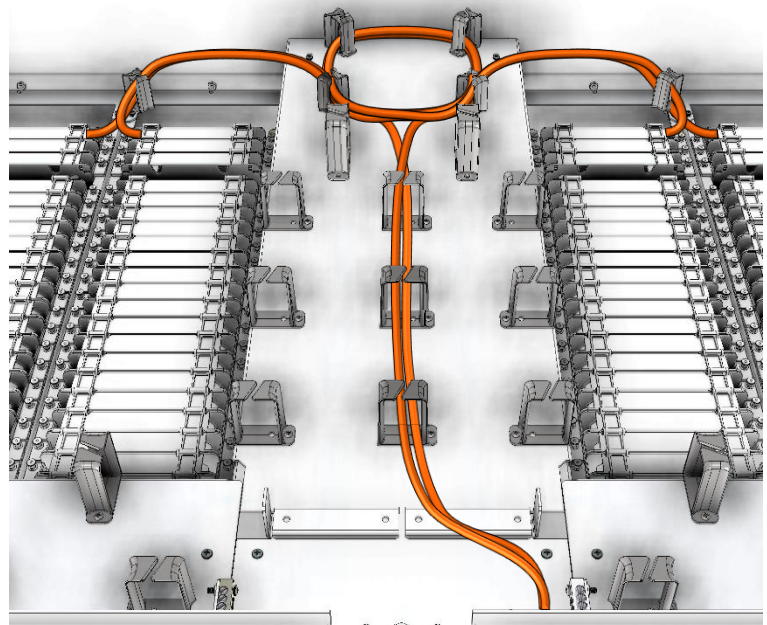

3.5 Insert distribution cable thru large cable port, tighten external nut and secure jacket with hose clamp.

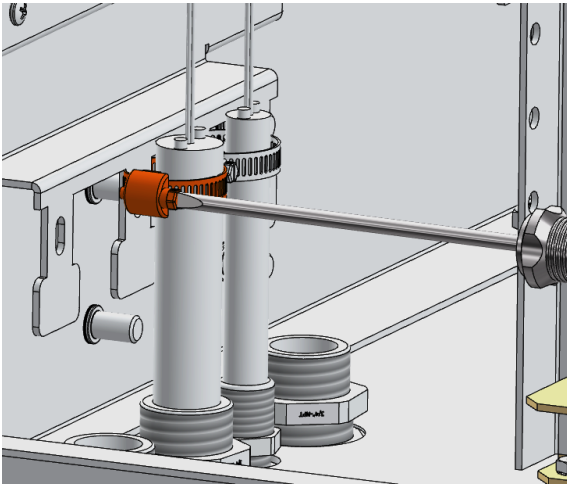

3.6 Lay strength member on back panel and clamp with provided bracket.

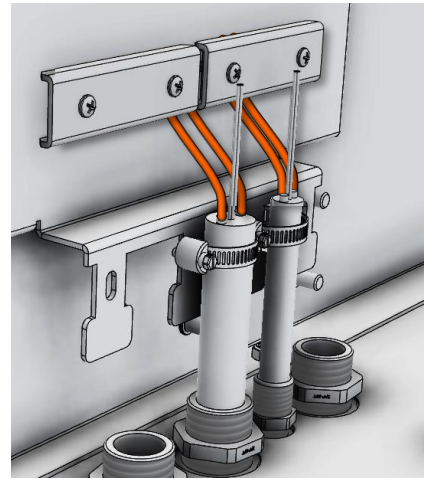

3.7 Remove the distribution cassette by releasing the mounting pins (located on both sides behind the cassette as shown), slide the cassette rearward.

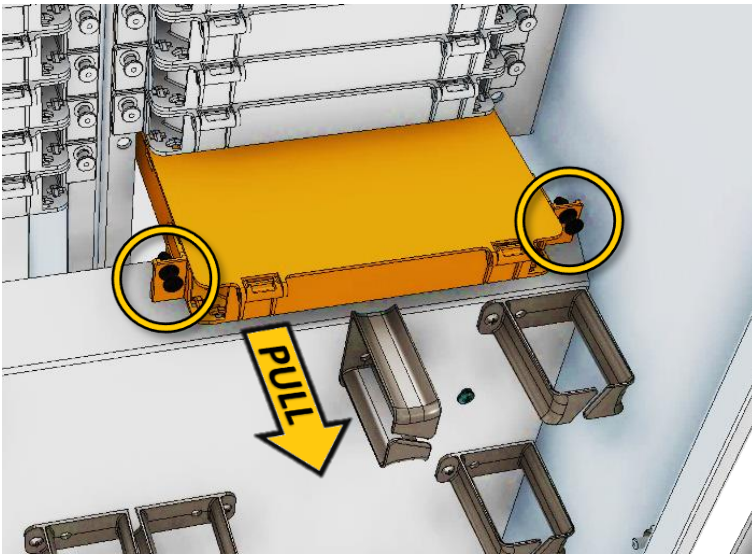

3.8 After making required splices inside of cassettes, manage distribution cables on provided management clips.

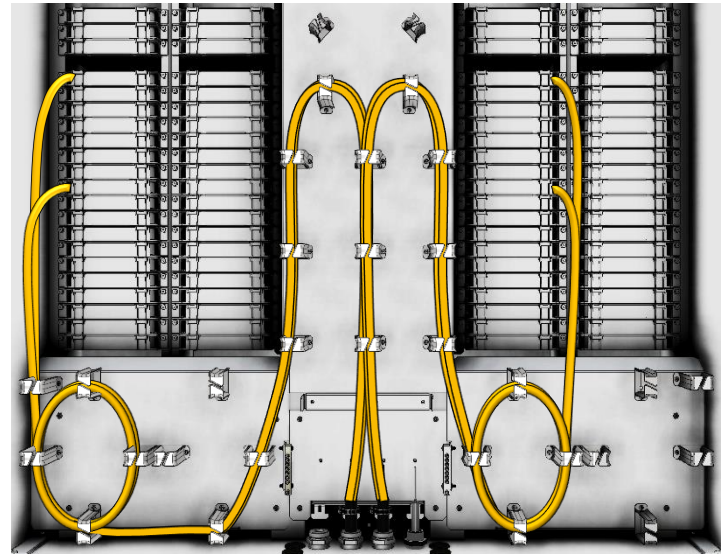

3.9 Reinstall cassettes by sliding into cabinet adapter first, rotating adapters towards front of cabinet, and securing into position by pressing the mounting pins.

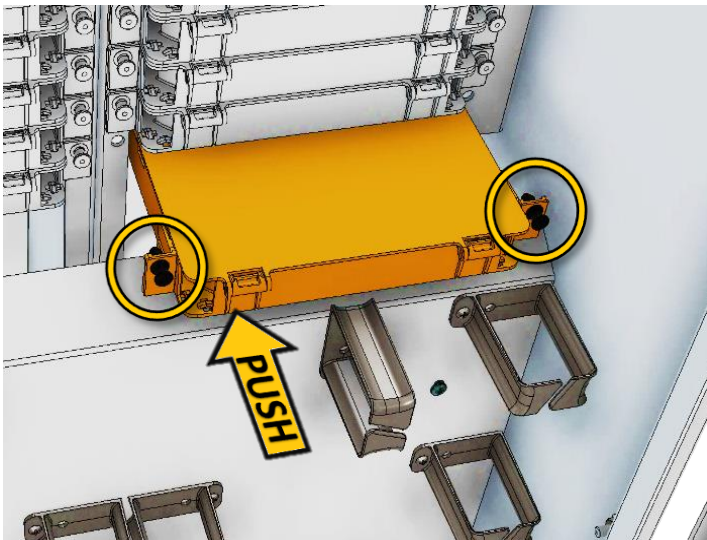

4. FOR SPLITTER INSTALLATION

4.1 Open front door with 216 tool.

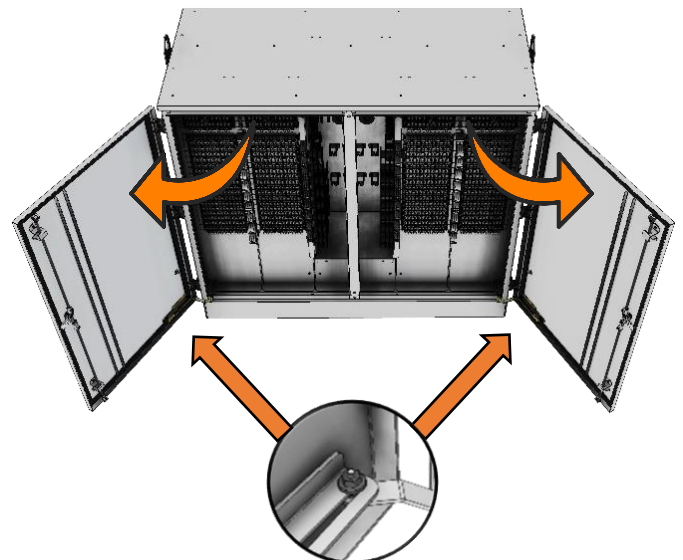

4.2 To install splitter onto mounting bracket, push top of mounting clip toward rear of cabinet. Catch bottom of splitter on bottom bracket and push top of splitter against top clip until it snaps into place.

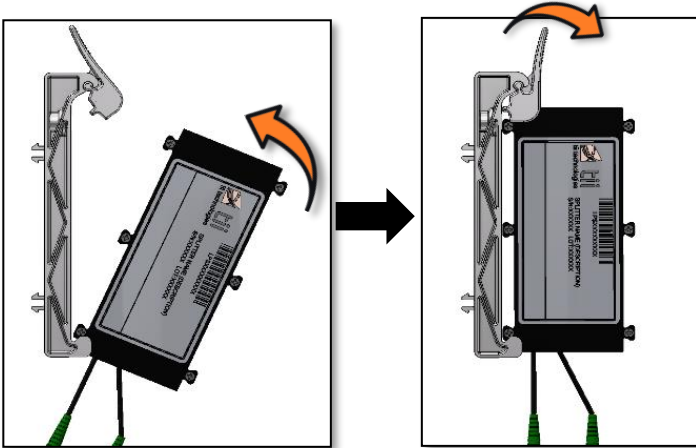

4.3 Connect splitter input legs to desired adapters on input area and route cable using the provided management clips as needed.

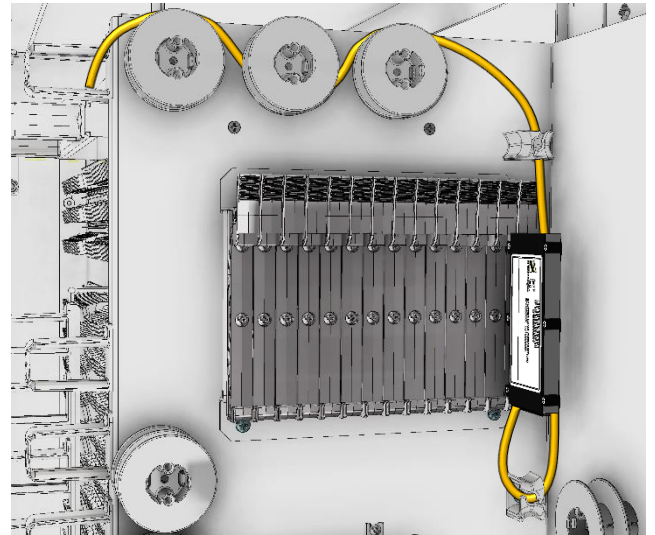

4.4 Connect splitter distribution legs to desired adapters on distribution field and route cable on provided management clips as needed.

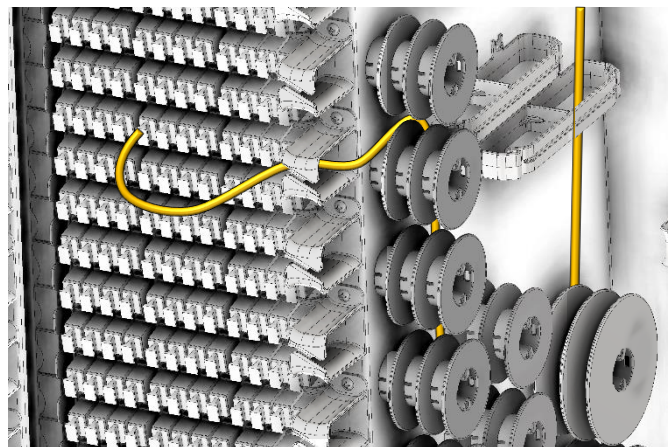
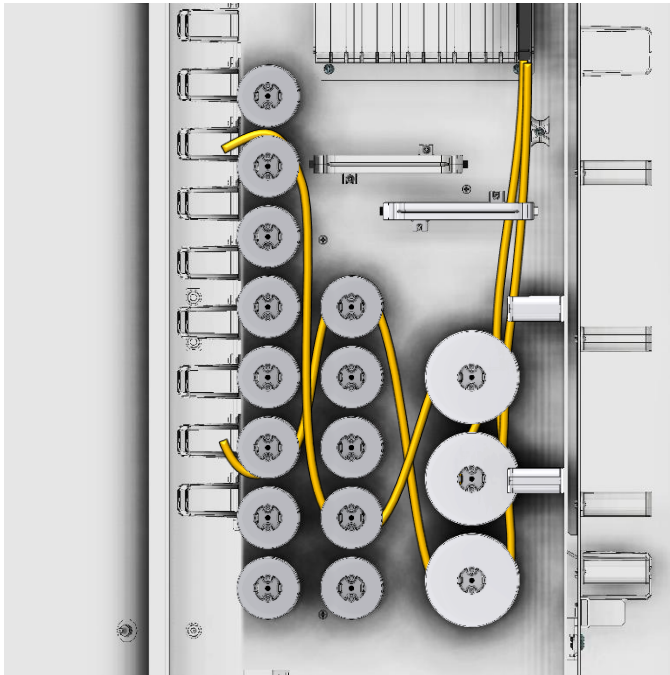
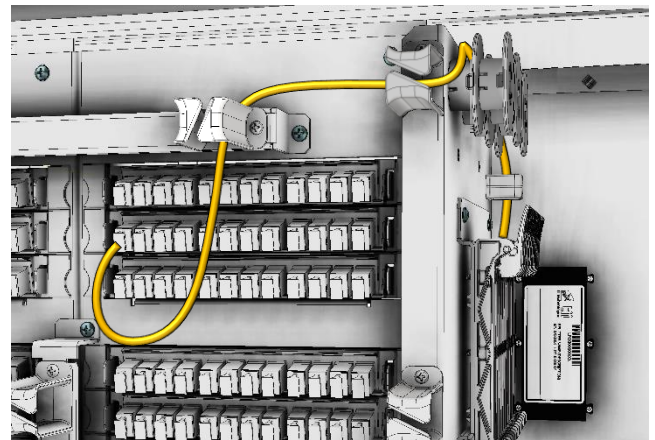

5. STORING UNUSED FIBER

Store unused splitter legs using the provided management clips as indicated below.

