

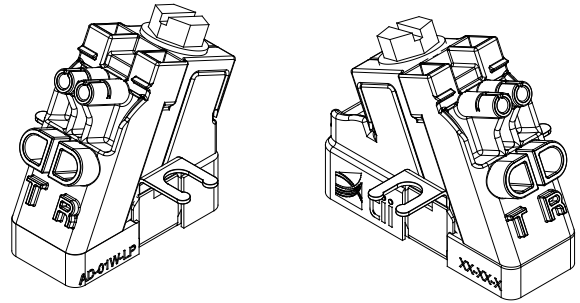

141 Rodeo Drive
Edgewood, NY 11717
Toll Free 888.844.4720
www.tiitech.com

Model AD-01W-LP, AD-01W-LP1
Station Protection Module



INSTALLATION NOTE

Description

1. The AD-01W-LP/AD-01W-LP1 Series Station Protector modules may be installed in a wide variety of housings.
2. The AD-01W-LP/AD-01W-LP1 Series Station Protector Module provides one upper and one lower port per line for ease of wiring and termination. It is equipped with a universal grounding and mounting tab.
3. All ports utilize tool-less IDC rockers. The upper ports accept 22-26 awg wire, the lower ports terminate 18.5 "F" drop - 24 awg wire. Both ports are terminated by the driver bolt mechanism.
4. The AD-01W-LP/AD-01W-LP1 modules are equipped with integral sealed test points for ease of troubleshooting.

NOTE

National Electric Code Requirement. The protector shall be installed per National Electric Code ANSI/NFPA 70, Article 800, Section C, and shall meet all applicable local safety codes. These modules shall be installed in enclosures evaluated to the requirement of UL497.

Installation

1. The Angle Driver is delivered with a universal grounding and mounting tab (See Figure 1). If installing a new module, break away the unwanted ground tab from the module using a pair of pliers and discard (See Figure 2). Install module on desired ground post and secure with washer and nut.

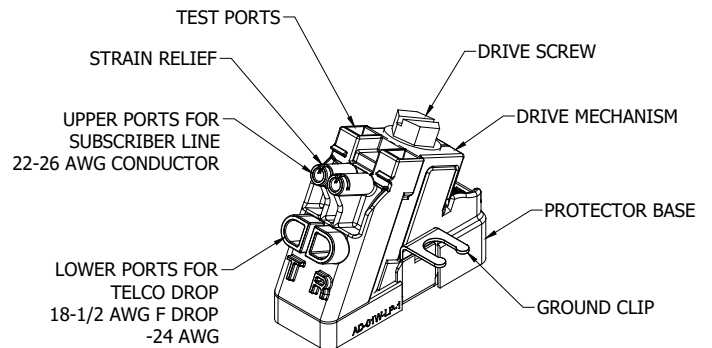

Figure 1

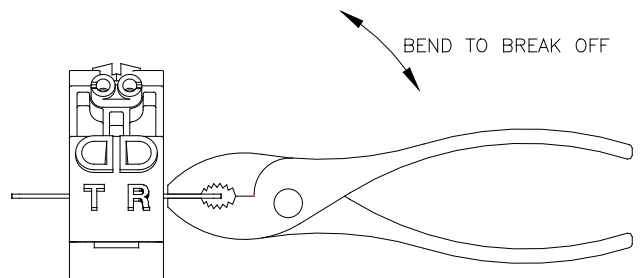

Figure 2

Wiring

1. The two upper ports of the Angle Driver are intended to terminate subscriber (customer) wires. Telco drop (feeder) wires must be terminated in the two lower ports of the Angle Driver.
2. Upper Port Subscriber Connections (See Figure 3) Subscriber terminations are already made at the factory. If it is necessary to re-terminate a subscriber wire, do so as follows:
3. Do not strip wire insulation. Make certain wire ends are cut flush with insulation.
4. Unscrew Angle Driver screw to the full upright position.
5. Fully insert the two subscriber wires into their respective tip and ring (color-coded) ports.
6. Insert while holding the two subscriber connection wires in place. **Ensure wires are fully inserted beyond the IDC connector (See Figure 7).** Tighten Drive Screw to the full down position. **Pull on wires to ensure proper connection. Wires should remain securely in place.**
7. Dress the wires through the strain relief slots to hold them in place (See Figure 3).

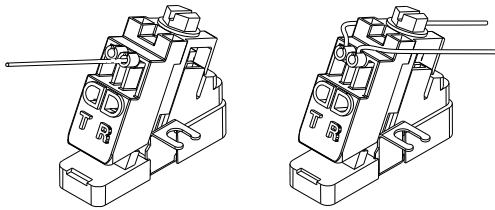

Figure 3

Lower Port Telco Connections (See Figure 4)

1. Do not strip wire insulation. Make certain wire ends are cut flush with insulation.
2. Unscrew Angle Driver screw to full upright position.
3. Fully insert the two feeder (telco) wires into their respective tip and ring (color-coded) ports. **Ensure wires are fully inserted beyond the IDC connector (See Figure 7).**
4. While holding the two telco wires in place, tighten Drive Screw to full down position. **Pull on wires to ensure proper connection. Wires should remain securely in place.**

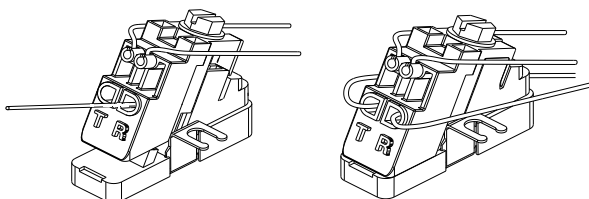

Figure 4

Testing

1. Feeder and subscriber wires must be segregated between the upper and lower ports to facilitate isolation testing (See Figure 5).

Upper and Lower Port Connected

1. With Driver in the fully closed position, insert test clips into tip/ring test port access holes located at top of driver. Perform customary tests.

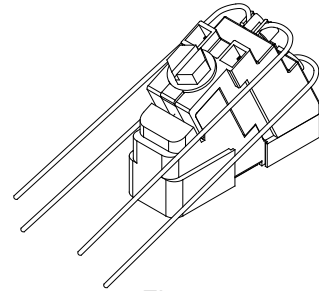

Figure 5

Testing Subscriber Connections

1. Loosen drive screw so driver is in the full upright position.
2. Remove telco wires from lower ports of driver.
3. Tighten drive screw so driver is in the full down position.
4. With Driver in the fully closed position, insert test clips into tip/ring test port access holes located at top of driver. Perform customary tests.

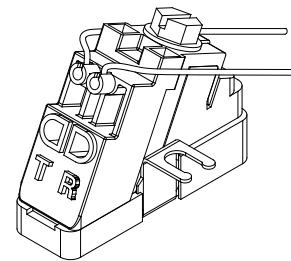

Figure 6

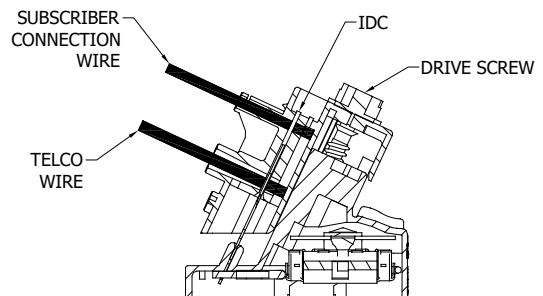

Figure 7