

Warranty: If this unit fails during the warranty period, contact tii customer service to authorize return. Unit may be returned prepaid.

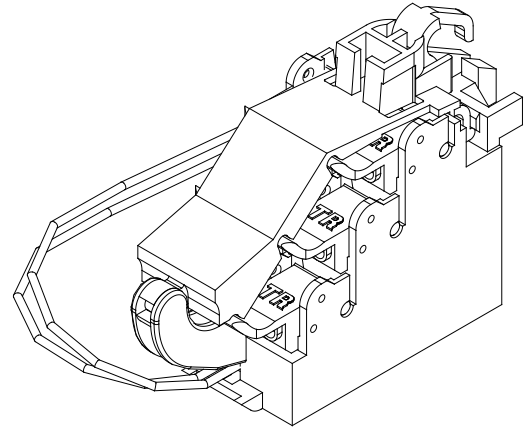

141 Rodeo Drive
Edgewood, NY 11717
Toll Free 888.844.4720
www.titech.com

Model 90-3
SEALED BRIDGING MODULE



Installation Note

CAUTION: The Product shall be installed in a manner to comply with applicable national and local safety codes.

ATTENTION : Le produit doit être installé de manière à se conformer aux réglementations nationales et locales applicables en matière de sécurité.

Description

1. The 90-3 Sealed Bridging Module provides sealed IDC terminations for connecting six additional extensions to an existing phone line. The module can be installed directly into all Tii Network Interface Devices and can be adapted to fit into a CAC 7600 footprint using an optional adapter.

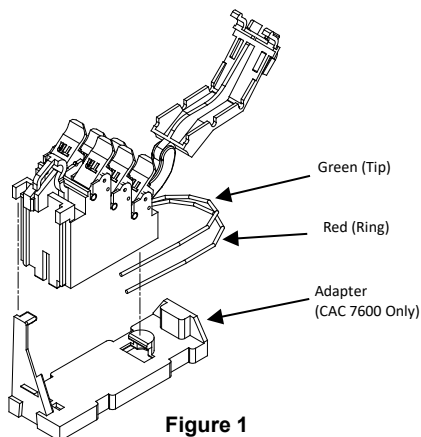

Installation

Installing the 90-3 into a Tii 3600/3700/9600/5300 Series NID

1. Locate the Network Interface Device
2. Unlock the subscriber access cover screw using a standard screwdriver (Figure 2).
3. Identify the appropriate line position to add the bridging module.
4. Snap the bridging module to the base as shown in Figure 3. For installation into a Tii 3600/3700/9600/5300 Series NID, the adapter is not required.
5. Terminate wire leads (Tip/Ring) from the bridging module to terminals on the existing Customer Bridge Module.
6. Do not strip wire insulation from wires to be terminated to CBM.
7. Lift all CBM rockers to the open position as shown (see Figure 1).
8. Hold the customer telephone wires between thumb and index finger (approx. 1/8" separation between wires).

Telco Shield Screw Telco Access Screw

Figure 2

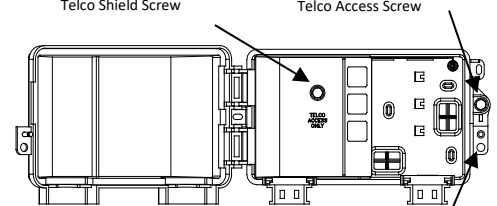

Subscriber Access Screw

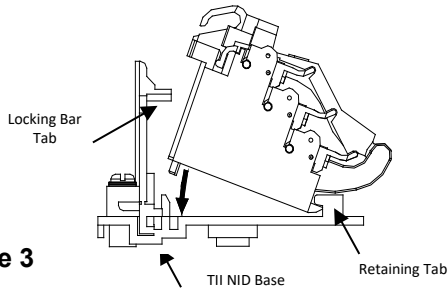

Figure 3

✓ **NOTE: Wires should be aligned to the corresponding holes. Green wire to the "T" (GRN) labeled wire guide and the Red wire to the "R" (RED) labeled wire guide.**

9. Insert wires into wire guides at the same time until they bottom out.
10. While holding wires in wire guides, terminate rocker with thumb (lower rocker all the way).
11. Terminate additional pairs to rockers as required.
12. Assure all rockers are in the down position and close customer security cover.
13. Test for unit operation.
14. After wiring is complete, close and secure NID cover (Figure 2).

Installing the 90-3 Sealed Bridging Module into A CAC 7600 Network Interface

1. Locate the Network Interface Device.
2. Unlock the cover (similar to Figure 2).
3. Identify the appropriate line position in the NID.
4. Snap the bridging module into the adapter, then into the base as shown in Figure 4.
5. Terminate wire leads (Tip/Ring) from the bridging module to terminals on the existing Customer Bridge Module.
6. Lift all CBM rockers to the open position as shown (see Figure 1).
7. Hold the customer telephone wires between thumb and index finger (approx. 1/8" separation between wires).

✓ **NOTE: Wires should be aligned to the corresponding holes. Green wire to the "T" (GRN) labeled wire guide and the Red wire to the "R" (RED) labeled wire guide.**

8. Insert wires into wire guides at the same time until they bottom out.
9. While holding wires in wire guides, terminate rocker with thumb (lower rocker all the way).
10. Terminate additional pairs to rockers as required.
11. Assure all rockers are in the down position and close customer security cover.
12. Test for unit operation.
13. After wiring is complete, close and secure NID cover (Figure 2).

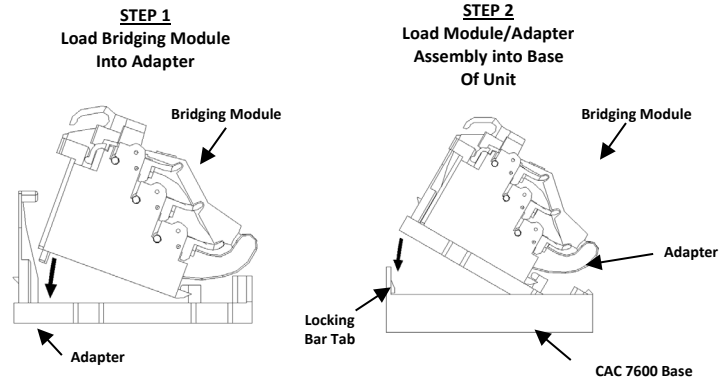

Figure 4