

372S-4G Series

GIGABIT ETHERNET PRIMARY PROTECTOR



141 Rodeo Drive
Edgewood, NY 11717
Toll Free 888.844.4720
www.tiitech.com

Model: 372S-4G
MATERIAL ID# 11344449

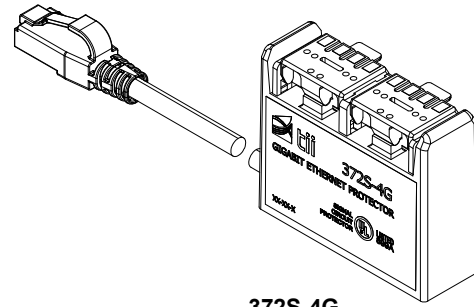

372S-4G

Installation Note

Description

1. The Tii 372S-4G Series provides primary surge protection to the Gigabit Ethernet networks.
2. The connections to the cable that is exposed to OSP surge events are provided through the IDC connections. Depending on the protector version, the connections to the ONT are provided through either a terminated male RJ45 connector or a sealed tooless IDC pigtail on the end of the CAT6 cable stub.
3. Each module is capable of terminating 22-24 AWG solid copper wires.

Features

Figure 1

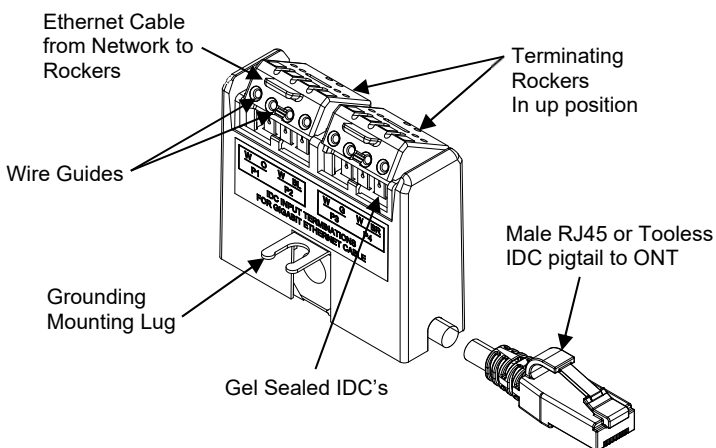

Caution: National Electric Code Requirements

The protector shall be installed per the National Electric Code, and shall meet all applicable local safety codes. In order for the surge protector to perform it must be properly grounded as per the National Electric Code.

Installation

1. For proper mounting and grounding of the Ethernet protector, a traditional 10-32 binding post is required (if not available, it may be purchased through Tii)
2. Remove the Ethernet primary protector module from the plastic bag and inspect; if damaged, replace with an undamaged protector module.
3. Using a 3/8" wrench unscrew the binding post nuts to slide the protector module in place.
4. Terminate one end of the grounding conductor (No. 6 AWG) on the ground stud / binding post and the other end to an appropriate ground source (See Figure 4).
5. Torque down the ground nut to secure the protector module and grounding wire in place.

WIRING For 372S-4G

1. Lift the rockers to the up (disengage) position (See Figure 1).
2. All eight wires of the Ethernet cable from network are terminated on the IDC's of the protector module.
3. Strip the outer jacket of the Ethernet cable from network & untwist about 1" of wire of the cable pairs.
4. Insert the unstripped wires through the wire guide holes in the left rocker until all wires bottom out in the rocker. Be sure to terminate the colored pairs of wires with the corresponding colors on the rockers.
5. Hold the wires in place and lower the rocker to its terminated position using thumb (See Figure 2).
6. Repeat wiring steps 4 & 5 for the right rocker.
7. Visually inspect that the wires are fully inserted and terminated properly.

- Insert the RJ45 of the protector module into the Ethernet RJ45 jack port of the ONT, located in the enclosure.

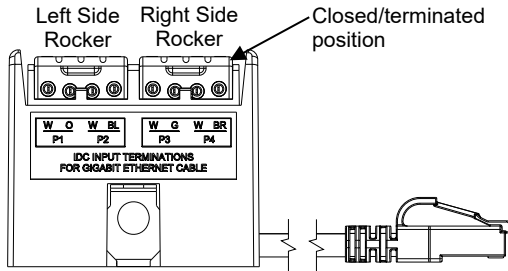
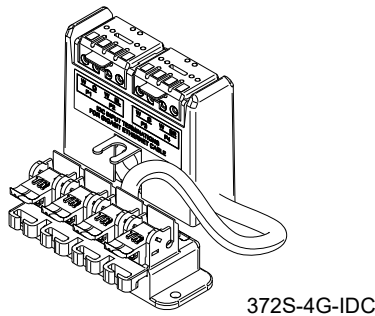

Figure 2



WIRING For 372S-4G-IDC

- Follow steps 1 through 6 as per the above instructions to wire the 372-4G unit.
- To wire the toolless IDC pigtail to ONT, lift the rockers to the up (disengaged) position (See Figure 3).
- DO NOT strip the wires. Hold the wire pairs to be terminated between thumb and index finger. Insert wires into wire guides simultaneously until they bottom-out. While holding wires in position, terminate rocker by lowering to the full DOWN position (See Figure 3). Be sure to terminate the colored pairs of wires with the corresponding colors on the rockers.
- Repeat wiring steps 2 & 3 for the remaining rockers.
- Visually inspect that the wires are fully inserted and terminated properly.
- To keep wire pairs organized, route them through the molded wire looms as shown in Figure 3.

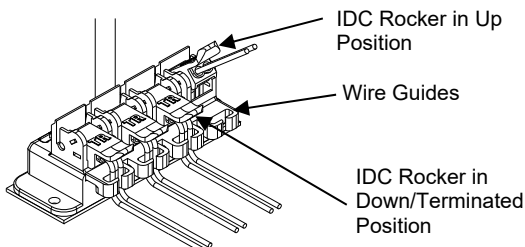
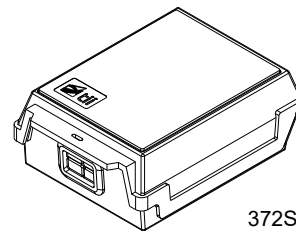

Figure 3



372S-4G-IDC-1

Installation For 372S-4G-IDC-1

- The TII 372S-4G-IDC-1 Outdoor Enclosure consists of one protector module with a sealed toolless IDC pigtail in a top hinged enclosure with integral ground stud (See Figure 4).
- The plastic base is molded with knock out holes for mounting.
- A flexible grommet is located in the center of the base to provide a seal for conductor wiring. (See Figure 4.)
- Mount the Enclosure so as to minimize the possibility of dirt or moisture getting into the protector.
- Mount the Enclosure vertically on a flat surface using appropriate hardware.
- Insert the grounding conductor and all wiring through the entrance port grommet in the base of the enclosure (See Figure 4).
- Terminate one end of the grounding conductor (No. 6 AWG) on the ground stud / binding post and the other end to an appropriate ground source (See Figure 4).
- For wiring the Protector Module, follow steps 1 through 6 as per the instructions to wire the 372-4G-IDC unit.

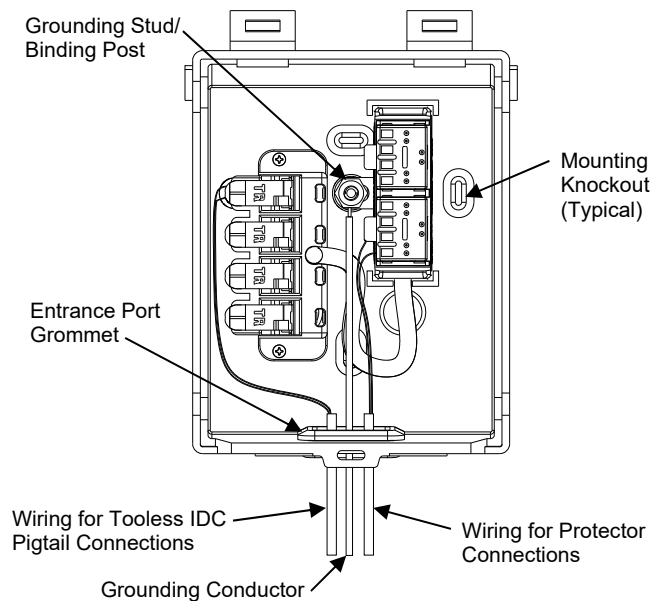

Figure 4