

## INSTALLATION NOTE

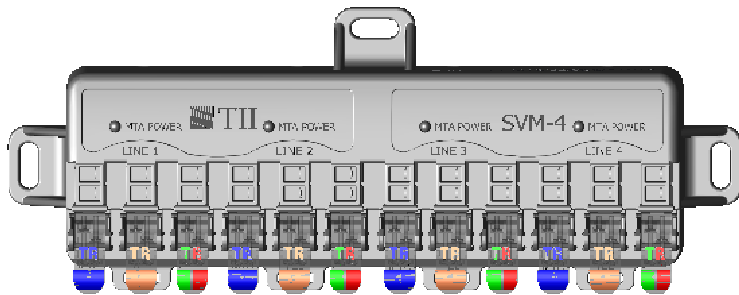

**SVM-4-0**

### 1. DESCRIPTION

- 1.1 The tii SVM-4 Series Multi-Line Switchable Voice Module is used when porting existing telephone numbers.
- 1.2 The tii SVM-4 has been designed to provide automatic switching of a customer's telephony provider from Telco to Digital Voice Service automatically after installation when the number is ported.
- 1.3 The tii SVM-4 can come equipped with an optional secondary telephone line surge protection to enhance the Digital Phone service reliability.
- 1.4 The SVM-4 should only be used for indoor applications, if mounting outdoors the SVM-4 should be mounted in a weatherproof housing.
- 1.5 The SVM-4 is powered from the Digital Voice Service line, and switches to Digital Voice Service after validating telephone ringing voltage presence on this line. The green LED will blink slowly when the SVM is receiving power from the Digital Voice Service Line.
- 1.6 The SVM-4 may be reset by using the reset push button accessible on the side wall of the device. The SVM-4 must be powered by the ATA / EMTA for the reset function to operate.
- 1.7 IDC rockers are used to terminate 26-22 AWG solid wire.

### 2. WARRANTY

- 2.1 See tii Warranty. If this unit fails during the warranty period, contact tii customer service to authorize return and return the unit prepaid. Units that fail due to normal wear or abuse should be discarded.

### 3. INSTALLATION (Line 1)

- 3.1 Remove the unit from the bag and inspect it for damage. If damaged, obtain another unit.
- 3.2 Locate a suitable flat, dry area to install the unit.
- 3.3 Prior to installing the SVM-4 pre-drill the (3) mounting location holes to accommodate #8 self tapping screws (See Figure 1).

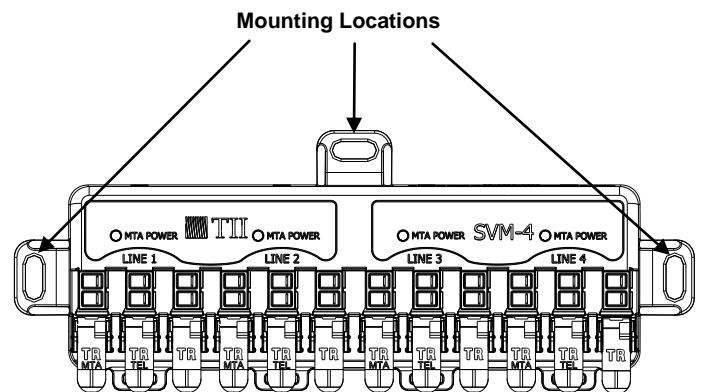

**Figure 1**

- 3.4 Lift the blue rocker for the digital voice service wires (MTA) to the full up position. DO NOT strip wires. (See Figs 2 & 3)
- 3.5 Insert the Digital Voice Service wires from ATA/EMTA into wire guides simultaneously until they bottom-out. While holding the wires in position, terminate them into the MTA (Blue) rocker by lowering it to the full DOWN position. (See Figs 2 & 3) If the ATA/EMTA is supplying power to the

SVM, the green MTA power LED provided on the line will start to blink.

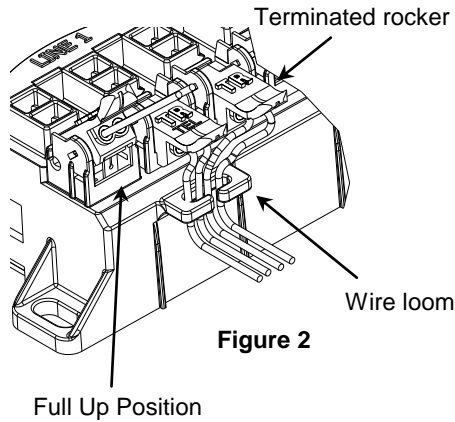

Figure 2

3.6 Disconnect the customer premise wiring from the Telephone Network Interface Device (NID). Straighten the ends of the wires, cut kinked and stripped ends. Lift the Green/Red rocker to full up position. Insert wires into the Customer wire rocker holes. While assuring that wires are fully inserted lower the rocker to fully seated position (See Fig 3).

3.7 Connect a wire pair from the Telephone NID to the rocker labeled TEL (orange). Follow procedure described above for the wire pair termination (See Figs 2 & 3).

3.8 To keep wire pairs organized, route them through the molded wire looms. (See Fig. 2)

#### 4 INSTALLATION (Lines 2-4)

4.1 Follow steps 3.4 to 3.8 to connect Line's 2-4 through the SVM-4.

#### 5 RESET

**IMPORTANT:** This unit **MUST** be reset during initial installation. Follow these instructions to reset the unit.

5.1 Confirm that the power is connected to the MTA (Blue) rocker of SVM-4 by observing green LED blinking.

5.2 **Gently** push the reset button once with a blunt object to ensure the service to the customer is from the Telco Service Provider (See Figure 4).

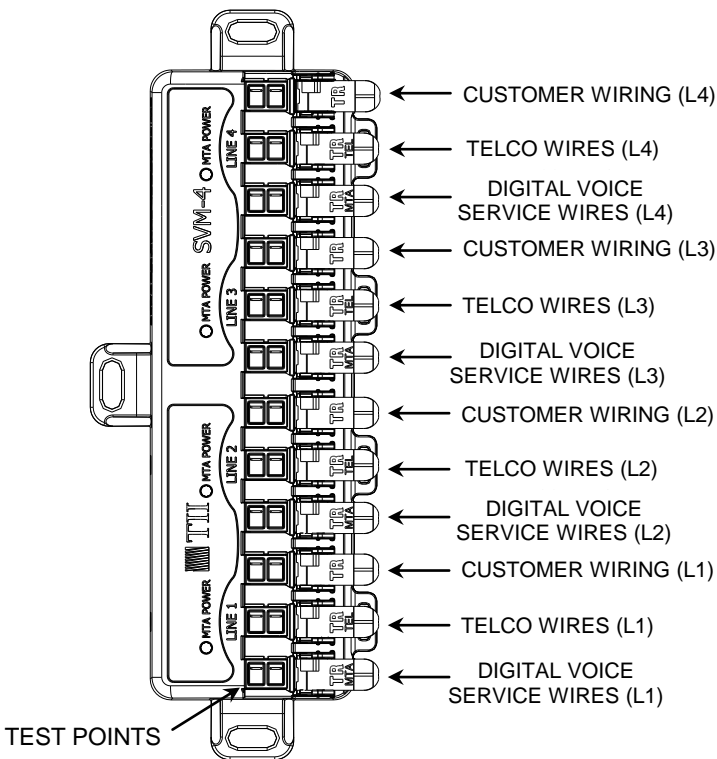

Figure 3

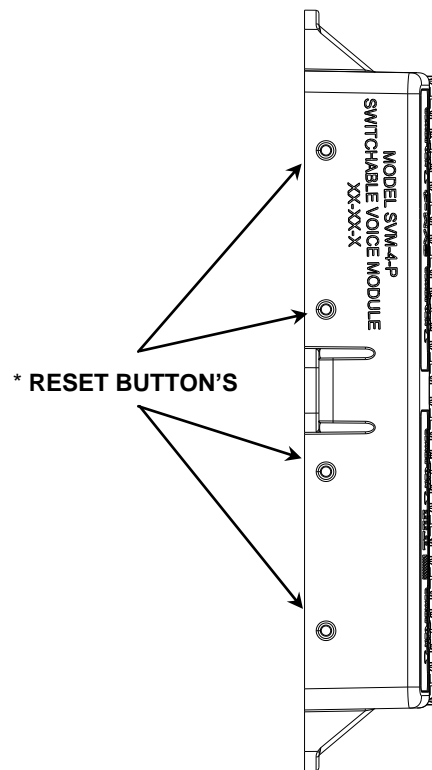

Figure 4

**NOTE:**  
THE RESET SWITCH IS DISABLED DURING RINGING VOLTAGE PRESENCE AND TEN SECONDS AFTER THE LAST RINGING VOLTAGE.

**CAUTION:**

**TO AVOID PERMANENT DAMAGE TO RESET  
BUTTON DO NOT USE EXCESSIVE FORCE  
OR A POINTED OBJECT TO ACTIVATE THE  
RESET BUTTON.**